



Designation: D1696 – 95 (Reapproved 2019)^{ε1}

Standard Test Method for Solubility of Cellulose in Sodium Hydroxide¹

This standard is issued under the fixed designation D1696; the number immediately following the designation indicates the year of original adoption or, in the case of revision, the year of last revision. A number in parentheses indicates the year of last reapproval. A superscript epsilon (ϵ) indicates an editorial change since the last revision or reapproval.

^{ε1} NOTE—Section 2.1 was updated Editorially in December 2019.

1. Scope

1.1 This test method² is intended for application to dissolving-type cellulose pulps prepared from cotton or wood. The procedure is not directly applicable to unrefined pulps for use in chemical conversion processes because solubility equilibrium may not be attained within the specified extraction time.

1.2 The values stated in SI units are to be regarded as standard. No other units of measurement are included in this standard.

1.3 *This standard does not purport to address all of the safety concerns, if any, associated with its use. It is the responsibility of the user of this standard to establish appropriate safety, health, and environmental practices and determine the applicability of regulatory limitations prior to use.*

1.4 *This international standard was developed in accordance with internationally recognized principles on standardization established in the Decision on Principles for the Development of International Standards, Guides and Recommendations issued by the World Trade Organization Technical Barriers to Trade (TBT) Committee.*

2. Referenced Documents

2.1 *ASTM Standards:*³

[D1193 Specification for Reagent Water](#)

¹ This test method is under the jurisdiction of ASTM Committee D01 on Paint and Related Coatings, Materials, and Applications and is the direct responsibility of Subcommittee D01.36 on Cellulose and Cellulose Derivatives.

Current edition approved Dec. 1, 2019. Published December 2019. Originally approved in 1959. Last previous edition approved in 2011 as D1696 – 95 (2011). DOI: 10.1520/D1696-95R19E01.

² This test method is an adaptation of the method designated CCA 8:55 by the Analysis Committee of the Central Committee of the Cellulose Industry of the Swedish Association of Pulp and Paper Engineers. This test method is also comparable with the TAPPI Tentative Standard T 235 m-58, Solubility of Pulp in Cold Sodium Hydroxide.

³ For referenced ASTM standards, visit the ASTM website, www.astm.org, or contact ASTM Customer Service at service@astm.org. For *Annual Book of ASTM Standards* volume information, refer to the standard's Document Summary page on the ASTM website.

[D1347 Test Methods for Methylcellulose](#) (Withdrawn 2003)⁴

[D1348 Test Methods for Moisture in Cellulose](#) (Withdrawn 2017)⁴

2.2 *TAPPI Standard:*

[T 429 Method for Alpha-Cellulose in Paper](#)⁵

3. Summary of Test Method

3.1 Pulp is steeped in a sodium hydroxide solution of a specified concentration for 1 h at 20°C. The soluble fraction is estimated by dichromate oxidation of the filtered steeping alkali. The concentration of sodium hydroxide used in the pulp extraction process must be reported as part of the analytical result. Sodium hydroxide concentrations of 10, 18, and 21.5 % are most frequently used. Data are reported as percent of dry sample weight.

3.2 The extraction procedure avoids dilution sequences, and therefore, the results are not comparable to data obtained by the alpha, beta, gamma methods of pulp fractionation (see TAPPI Method T 429). The terms “alpha-,” “beta-,” or “gamma-” cellulose must not be applied to any test values obtained by this procedure since they are defined only by the method of their determination.

3.3 The essential feature of the method is to prepare sodium hydroxide extracts and oxidize the soluble material with dichromate as described. Alternative methods of estimating dichromate by titration with ferrous ammonium sulfate and sodium thiosulfate are described.

4. Significance and Use

4.1 The measurement of soluble oxidizable components of cellulose in sodium hydroxide is indicative of the purity of the cellulose sample, since pure cellulose is insoluble in sodium hydroxide. The extracted components are typically hemicelluloses, which are naturally present in the wood.

⁴ The last approved version of this historical standard is referenced on www.astm.org.

⁵ Available from Technical Association of the Pulp and Paper Industry (TAPPI), P.O. Box 105113, Atlanta, GA 30348; 15 Technology Parkway South, Norcross, GA 30092.

Differences in pulp purity can have a dramatic impact on the processing and properties of the cellulose derivatives produced from the pulp.

5. Apparatus

5.1 *Constant-Temperature Bath*—A water bath maintained at $20 \pm 0.2^\circ\text{C}$.

5.2 *Stirrer*—Mechanical stirrer as shown in Fig. 1. All parts in contact with solutions must be of stainless steel. The stirrer motor shall be a variable speed laboratory motor with 1500 rpm max speed.

5.3 *Fritted-Glass Filter Crucible*—A fritted-glass filter crucible, coarse porosity (pore size 40 to 60 μm), of 30-mL capacity.

5.4 *Electrometric Titration Apparatus*—For estimation of dichromate by titration with ferrous ammonium sulfate. An indicator may be used as described in 8.6, but for rapid, accurate analysis an electrometric apparatus is recommended.

6. Purity of Reagents

6.1 Reagent grade chemicals shall be used in all tests. Unless otherwise indicated, it is intended that all reagents shall conform to the specifications of the Committee on Analytical Reagents of the American Chemical Society,⁶ where such specifications are available. Other grades may be used, provided it is first ascertained that the reagent is of sufficiently high purity to permit its use without lessening the accuracy of the determination.

6.2 Unless otherwise indicated, references to water shall be understood to mean reagent water conforming to Specification D1193.

⁶ ACS Reagent Chemicals, Specifications and Procedures for Reagents and Standard-Grade Reference Materials, American Chemical Society, Washington, DC. For suggestions on the testing of reagents not listed by the American Chemical Society, see *Analar Standards for Laboratory Chemicals*, BDH Ltd., Poole, Dorset, U.K., and the *United States Pharmacopeia and National Formulary*, U.S. Pharmacopeial Convention, Inc. (USPC), Rockville, MD.

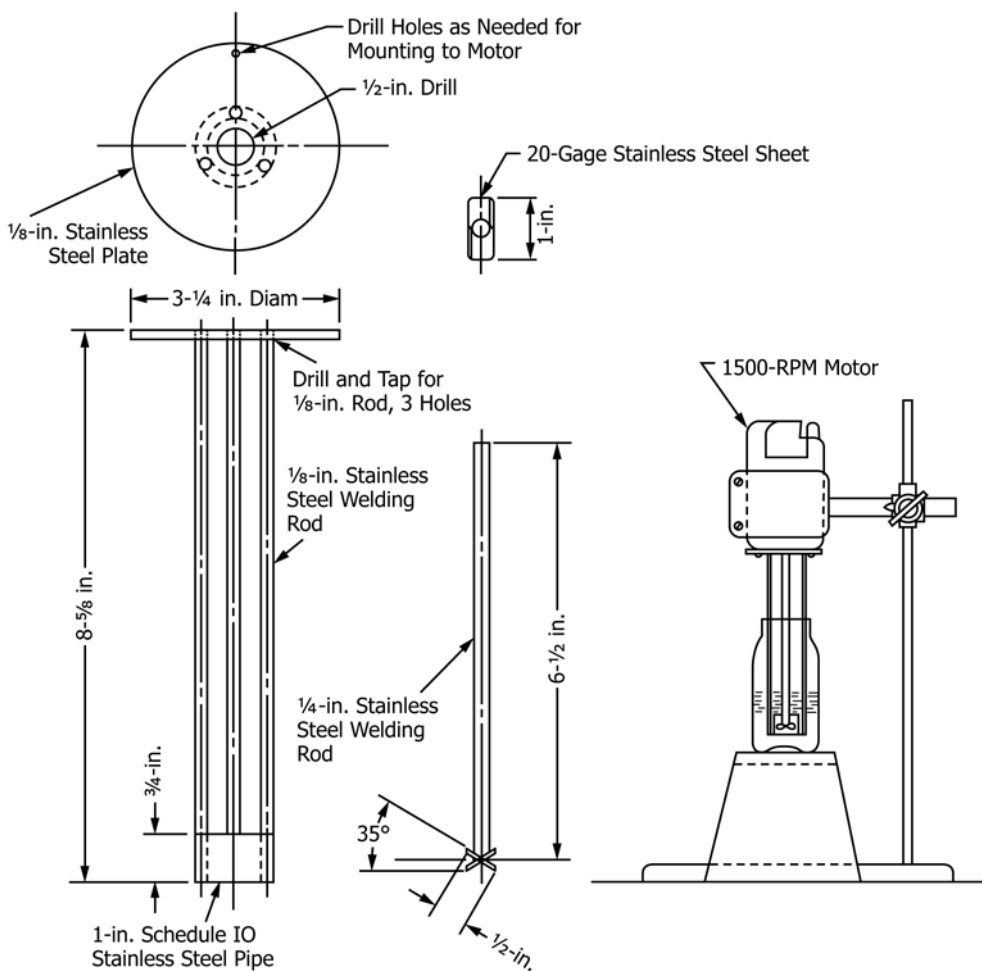

		Metric Equivalents							
in.	mm	1/8	1/4	1/2	3/4	1	3/4	6 1/2	8 5/8
		3.2	6.4	12.7	19.0	25.4	82.6	165.1	219.1

FIG. 1 Design Details of Mechanical Stirrer